



TECHNICAL DATA / FEATURES

- dimensions: $\phi 80 \times 102$, $\phi 84 \times 106$
- luminous flux of the LED module: 500 lm
- luminous flux of the lamp: 250 lm
- maximum power: 9W
- nominal voltage: 12V-24V DC
- permissible power supply voltage: 10.5V-30V DC
- source of light: 3 x LED
- colour temperature: 5000-7000K
- light distribution angle: $33^\circ \times 12^\circ$
- IP rating: IP67, IP69K, IP66
- work temperature: $-40^\circ\text{C} - +80^\circ\text{C}$
- housing's material: aluminium/plastic
- lens' material: glass
- built-in connectors: AMP Faston 250, Deutsch DT
- other: protection:
 - against overheating
 - against reverse polarisation
- bracket made of Inox steel



ADDITIONAL INFORMATION

Work lamps are used to illuminate working space near vehicles, tractors, slow-moving machines and any other places where indicated voltage is available.

The lamps comply with EMC Directive 2004/108/EC. They do not emit electromagnetic interference as well as they are resistant to it's influence.

Correct polarity required.

Mounting: factory prepared places, built-in to vehicle's recess, as a freestanding on the body work. Versions with the bracket can be installed on a vehicle in an upright or upside-down position.

It is possible to install needed connectors for a version with cable (on request).

Useful parts while installing:

- deutsch plug DT06-2S 2-pin - cat. No. A.07135
- AMP SuperSeal 1,5 plug 2-pin - cat. No. A.07137
- AMP Faston 250 plug 2-pin - cat. No. A.07138

DIMENSIONS

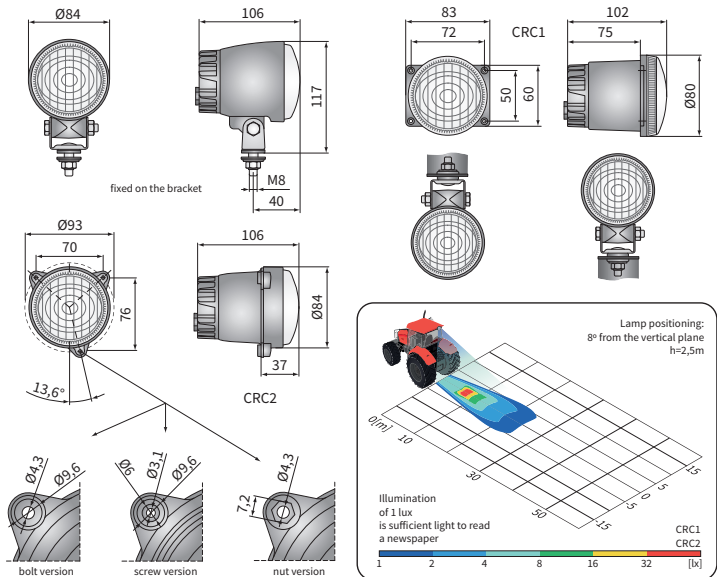

Cat. number	Diameter		IP rating	IP66	IP67	IP69K	Accessories	LED module 12V-24V	cable 0.5 m	cable 0.15 m	Mounting method	in recess	installed vertically up	Bracket	4 bolts	M8	3 screws	3 bolts	3 nuts	Connectors	AMP Faston 250	Deutsch DT	AMP SuperSeal 1,5	Cap / Pin
	$\phi 80$	$\phi 84$																						
CRC1.48101	✓							✓				✓												
CRC1.48121	✓			✓				✓				✓												
CRC1.48131	✓				✓			✓				✓												
CRC1.48111	✓				✓			✓				✓												
CRC1.48112	✓				✓			✓				✓												
CRC2.48201		✓						✓				✓												
CRC2.48203		✓		✓				✓				✓												
CRC2.48204		✓			✓			✓				✓												
CRC2.48202		✓			✓			✓				✓												
CRC2.48211		✓			✓			✓				✓												

Cat. number	Diameter		IP rating	IP66	IP67	IP69K	Accessories	LED module 12V-24V	cable 0.5 m	cable 0.15 m	Mounting method	in recess	installed vertically up	Bracket	4 bolts	M8	3 screws	3 bolts	3 nuts	Connectors	AMP Faston 250	Deutsch DT	AMP SuperSeal 1,5	Cap / Pin
	$\phi 80$	$\phi 84$																						
CRC2.48213		✓		✓				✓				✓												
CRC2.48214		✓		✓				✓				✓												
CRC2.48212		✓		✓				✓				✓												
CRC2.48221		✓		✓				✓				✓												
CRC2.48223		✓		✓				✓				✓												
CRC2.48224		✓		✓				✓				✓												
CRC2.48222		✓		✓				✓				✓												
CRC2.48231		✓		✓				✓				✓												
CRC2.48233		✓		✓				✓				✓												
CRC2.48234		✓		✓				✓				✓												
CRC2.48232		✓		✓				✓				✓												